

Name: Sven Zünd
Date: März 2013
Track: Bütschwil

Track Conditions
 Size: Open Med. Tight
 Traction: High Med. Low
 Surface: Smooth Med. Bumpy

Result
 Race Time / Lap: _____
 Best Lap (1Lap): _____

Front Suspension

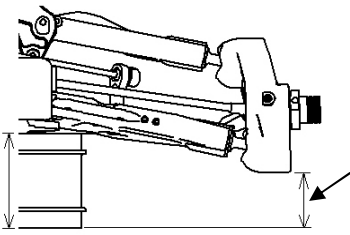

Tension Rod: E2107A (Long)
 E2107B (Short)

Upper Arm Position:

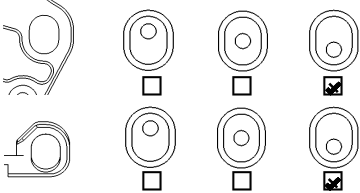

Ride Height: 27mm
 Toe Angle: 0
 Kingpin Ball Spacer: 1 shim
 Rebound Stop: 98mm
 Wheel Hub: std
 Anti Roll Bar: 2.2mm
 Upper Arm Spacer: 2
 Lower Arm Spacer: 0

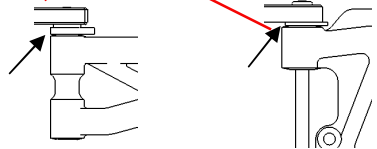

Lower Arm Position (Kick Up):

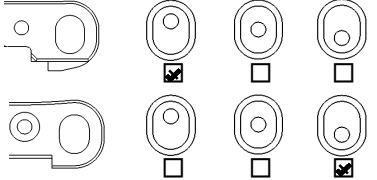

Front Shocks

Piston: 5x1.35H
 Oil: 30 Asso
 Spring: 1.5/8.0T
 Spring Adj: _____

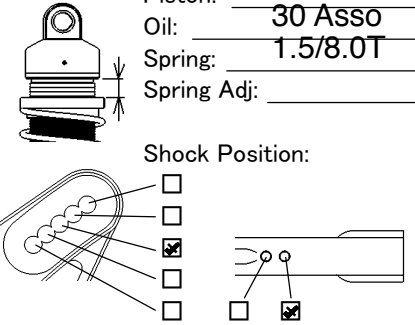

Shock Position:

Pivot Ball Position: Front Rear
 Damper Stay: E2502 (Aluminum)
 E2511 (CFRP)

Steering Ackerman

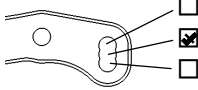

Rear Suspension

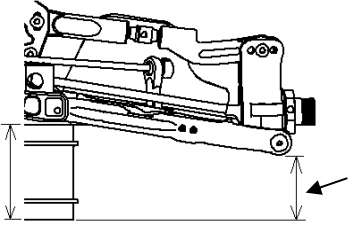

Upper Arm Position:

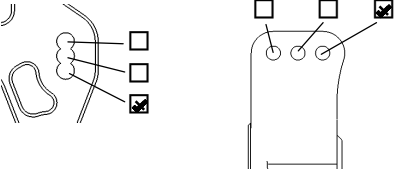

Lower Arm Position (Anti-Squat):

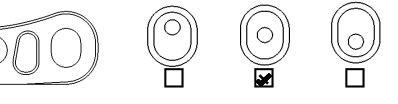

Ride Height: 28
 Camber Angle: 2
 Rebound Stop: 115
 Anti Roll Bar: 2.6
 Lower Arm Spacer: 1
 Upright Spacer: Mitte

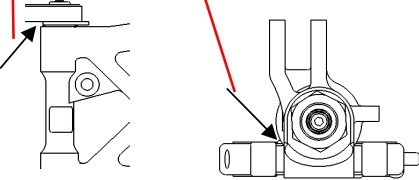

Lower Arm Position (Toe Angle):

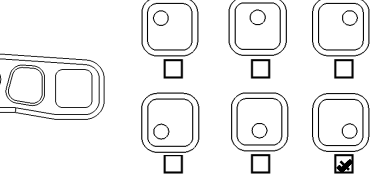

Rear Shocks

Piston: 5x1.35H
 Oil: 27.5 Asso
 Spring: 1.5/8.5T
 Spring Adj: _____

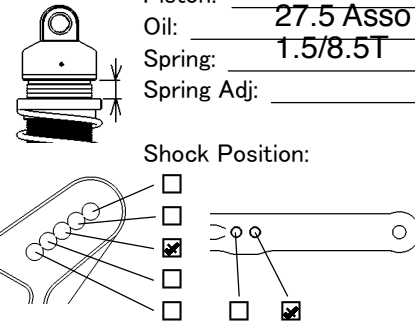

Shock Position:

Pivot Ball Position: Front Rear
 Damper Stay: E2503 (Aluminum)
 E0535 (CFRP)

Engine
 Type: Bonito XLBS
 Gasket: 41029
 Muffler: 9901 Strong
 Engine Mount: E0701 (Standard) E0703 (One Piece)

Plug: 6TGC
 Reducer: 5.4
 Fuel: Meccamo 25%

Diff. Oil
 Front: 4000
 Center: 5000
 Rear: 3000

O-Ring: _____ pcs.
 _____ pcs.
 _____ pcs.

Tires

Type: Starpin	Front	Rear
Compound: Super Soft		Starpin
Inserts: Aka Rot		Super Soft
Wheel: Aka Evo		Aka Rot
		Aka Evo

Clutch
 Clutch Bell: 13
 Clutch Shoes: 3 Alu Std
 Clutch Spring: 3x1.0

Spur Gear: 46

Body/Wing

Body: Std
 Wing: Std

Wing Position:

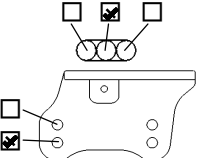

Comments:
 Lenkplatte anderstrum als Std
 Messing schrauben vorne im lenkhebel